

MATRIX 100™



Compact imager for value-added integrated solutions using 1D and 2D barcodes



EASY INTEGRATION

Designed for easy integration and simple installation, the Matrix 100 provide ready-to-use versatile solutions for kiosks and machine manufacturers. The Matrix 100 can be easily integrated with little effort in different enclosures from multiple sides with its small regular size and various fixing points.

MAXIMUM RELIABILITY

The Matrix 100 is made to last with a durable design for maximum uptime. You can rely on it for both indoor and outdoor applications with the IP54 sealing, the UV protected scratch resistant output window, the wide range operating temperature and the great resistance to accidental drops, shock, and vibrations. The RS-232 model has an integrated cable while the USB model is equipped with a locking clip to prevent the USB cable from coming loose or disconnecting.

The 2-year factory warranty proves the Matrix 100 has been designed to last.

TOP PERFORMANCE

The Matrix 100 features the most advanced Megapixel sensor technology with distinctive red illumination technology with adjustable brightness for outstanding reading performance. The wide angle optics allows snappy scanning of any 1D and 2D barcodes and it starts reading at almost contact while offering improved motion tolerance and first pass decoding of fast-moving codes.

The Matrix 100 is the perfect solution when small dimensions, simple integration and performance are the key drivers. The Matrix 100 allows an easier integration in OEM machines, making this product ideal for customers belonging to Chemical/Biomedical Industry and Print & Apply applications. Additionally, this imager is perfect for entry level applications in the Factory Automation arena: Electronics, Packaging and Food/Beverage.

BEST FEEDBACK

Datalogic's 'Green Spot' technology coupled with a high visibility top-front LED and integrated loud beeper with adjustable intensity provide superior good-read feedback.

FEATURES

- Compact dimensions for easy installation and simple integration
- Wide angle 1 MP optics for superior scanning and Depth of Field
- Advanced motion tolerance optics for first pass reading of any moving barcode
- Automatic sensing, software, external, manual trigger options available
- Datalogic distinctive red illumination technology with adjustable brightness
- Intuitive Blue Dot LED aimer for easier targeted scanning
- Superior good-read feedback (Datalogic's 'Green Spot' technology, high visibility top-front LED and integrated beeper with adjustable intensity)
- Omnidirectional reading of 1D, 2D and postal codes plus stacked, composite codes and dot codes; Digital Watermarks on red illumination models
- USB and RS-232 communication options
- 1 Digital input plus 1 Digital output software programmable (available in a RS-232 model)
- Water and Particulate Sealing Rating: IP54
- Disinfectant-Ready enclosure withstands cleaning with harsh disinfectant solutions
- EASEOFCARE Service Plans offer a wide range of service options to protect your investment, ensuring maximum productivity and ROI.

INDUSTRY - OEM APPLICATIONS

- Electronics: Track and Trace PCB board manufacturing
- Factory Automation: Print & Apply – label verification
- Factory Automation: Food & Beverage – traceability
- OEM: Kiosks: ticketing machine
- Healthcare: Clinical Lab – vials identification
- Chemical and biomedical analysis machine



MATRIX 100

TECHNICAL SPECIFICATIONS

DECODING CAPABILITY

1D / Linear Codes	Auto discriminates all standard 1D codes including GS1 DataBar™ linear codes.
2D Codes	Aztec Code; China Han Xin Code; Data Matrix; MaxiCode; Micro QR Code; QR Code; Dot Code; Dot Matrix
Postal Codes	Australian Post; British Post; China Post; IMB; Japanese Post; KIX Post; Planet Code; Postnet; Royal Mail Code (RM4SCC)
Stacked Codes	EAN/JAN Composites; GS1 DataBar Composites; GS1 DataBar Expanded Stacked; GS1 DataBar Stacked; GS1 DataBar Stacked Omnidirectional; MacroPDF; MicroPDF417; PDF417; UPC A/E Composites
Digital Watermarking	Digimarc Barcodes

ELECTRICAL

Current	Operating (Typical): < 225 mA Standby/Idle (Typical): Automatic Object Sense Mode: 115 mA Online & Serial OnLine Modes: 55 mA
Input Voltage	USB: 5 VDC +/- 5%; Serial: 5 - 14.0 VDC

ENVIRONMENTAL

Ambient Light	0 – 120,000 lux
Drop Resistance	Withstands repeated drops from 1.5 m / 5 ft onto a concrete surface
Vibration Resistance	Tolerates random vibration, 5 G, from 22 Hz to 300 Hz, 2 hours / 3 axes
Particulate & Water Sealing	IP54
Temperature	Operating: Matrix 100: -20 to 50 °C / -4 to 122 °F (suitable up to 55°C / 131 °F) Storage/Transport: -40 to 70 °C / -40 to 158 °F

INTERFACES

Interfaces	USB: USB (micro-USB connector) Serial: RS-232 (2 m straight cable DB9 connector)
Digital I/O	One SW Programmable digital input plus one SW programmable digital output on Serial model

PHYSICAL CHARACTERISTICS

Colors Available	Black; Other colors and custom logo options are available for minimum quantity purchase.
Dimensions	2.8 x 4.8 x 5.5 cm / 1.1 x 1.9 x 2.2 in
Weight	USB: 52 g / 1.8 oz (micro-USB connector) Serial: 152 g / 5.4 oz (2 m straight cable DB9 connector included)

READING PERFORMANCE

Image Capture	Graphic Formats: BMP, JPEG, TIFF; Greyscale: 256, 16, 2
Image Sensor	1 Megapixel: 1280 x 800 pixels
Field of View	51°H, 32°V
Light Source	Aiming: Blue LED's 470 nm Illumination: Red LED 617nm
Print Contrast Ratio (Min.)	15%
Motion Tolerance	70 IPS (EAN/UPC)
Frame Rate	60 full-frame/s
Reading Angle	Pitch: +/- 60°; Roll (Tilt): +/- 180°; Skew (Yaw): +/- 60°
Reading Indicators	Beeper (Adjustable Tone and volume); Datalogic 'Green Spot' Good Read Feedback; Top-Front Good Read LED (Adjustable brightness)
Resolution (Maximum)	1D Linear: 0.076 mm / 3 mils Data Matrix: 0.13 mm / 5 mils PDF417: 0.13 mm / 5 mils

READING RANGES

Typical Depth of Field	Minimum distance determined by symbol length and scan angle. Printing resolution, contrast, and ambient light dependent. Code 39: 5 mil: 4 to 30.0 cm / 0.16 to 11.8 in Code 39: 10 mil: 1.7 to 53.5 cm / 0.6 to 21.0 in Data Matrix: 10 mil: 3.5 to 23.5 cm / 1.3 to 9.6 in Data Matrix: 15 mil: 3.0 to 35.0 cm / 1.2 to 13.7 in EAN/UPC: 13 mil: 4.0 to 82.0 cm / 1.6 to 32.3 in PDF417: 10 mil: 1.5 to 35.0 cm / 5.9 to 13.7 in QR Code: 10 mil: 3.5 to 22.0 cm / 1.4 to 8.7 in
-------------------------------	---

SAFETY & REGULATORY

Agency Approvals	The product meets necessary safety and regulatory approvals for its intended use. The Quick Reference Guide for this product can be referred to for a complete list of certifications.
Environmental Compliance	Complies to China RoHS; Complies to EU RoHS
LED Classification	Illuminator Exempt group, Aiming Risk Group 1 according to IEC 62471

UTILITIES

Datalogic Aladdin™	Datalogic Aladdin configuration program is available for download at no charge.
OPOS / JavaPOS	OPOS and JavaPOS Utilities are available for download at no charge.
Remote Host Download	Lowers service costs and improves operations.

WARRANTY

Warranty	2-Year Factory Warranty
-----------------	-------------------------

Matrix 100

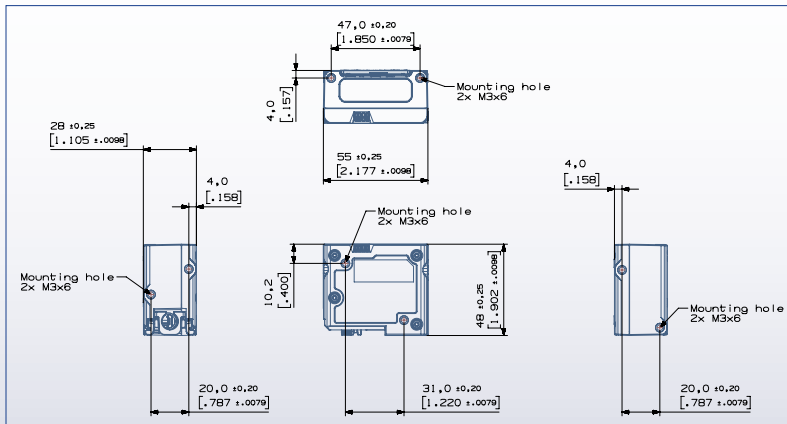

CODE	DESCRIPTION	CONNECTIVITY
901650001	MATRIX 100 210-000 RED USB STD	USB
901650002	MATRIX 100 210-010 RED SER+I/O STD	SERIAL+I/O